

## HANSA Receiver drier Ø75x229 STS 2525525050

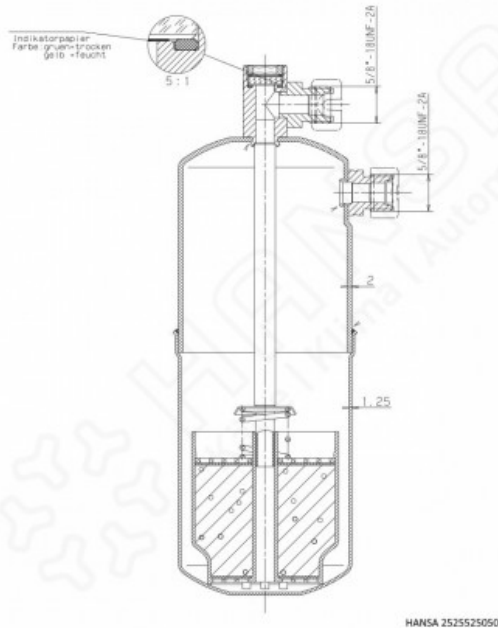

### Product short description:

Receiver drier with sight glass and indicator

Dimension (LxWxH): 229x75x75 mm

Weight: 0,937 kg

Part-No.: 2525525050

Made in Germany

### Product codes:

Reference: 2525525050

EAN13: 4251692917053

### Product description:

- Steel housing - capacity approx. 0.8m<sup>3</sup>
- Sight glass integrated
- Water absorption of 15g at 60°C (134a)
- Optionally available with holder, sensor and safety valve
- Filter cartridge with optional pure molecular sieve or addition of aluminium oxide
- Operation pressure up to 50bar
- Burst pressure resistant up to 100 bar
- Variable connection geometry
- Vibration or shock resistant (4G or 10G)
- Drying and filtering of fluids of groups I and II or safety class A2L (except NH3 and NH3-containing refrigerants).
- Approved for R1234yf, R1234ze, R290, R410a, R513a, R600a, R744a (up to the max. operating pressure stated below), among others.

### Product features:

Material design: Steel

Connection type: O-Ring

Connection: 5/8"-18UNF

**Product attributes:**

