

HANSA Cap nut 7/16"-20UNF HUT 2776868050

Product short description:

Cap nut 7/16"-20UNF

made of forged compact, therefore gas-tight and especially suitable for refrigeration systems.

Dimension (LxWxH): 14x15x14 mm

Weight: 0,011 kg

Part-No.: 2776868050

Made in Germany

Product codes:

Reference: 2776868050

EAN13: 4251692915073

Product description:

- Material: CW614N brass (acc DIN EN12164)
- Operating pressure up to 150 bar when used in conjunction with a corresponding valve insert in the connecting piece.
- Approved refrigerants: HFC / HFO / PFC / CFC / HC with the exception of NH3 containing refrigerants.

For a good seal during the assembly onto a stud or connector made from the same material a suitable seal like a O-ring or cap made from copper has to be used. Tightening torque for simple connection pieces 15-20 Nm, for connection pieces with thread for valve inserts valve inserts 7 - 10 Nm. As these connecting pieces have a slightly larger diameter, the collar of the connection piece can deform and the valve insert can then no longer be replaced.

Product features:

Material design: Brass
Connection: 7/16-20UNF
Width across flats AF: 14
Pressure range: 150 bar

Product attributes:

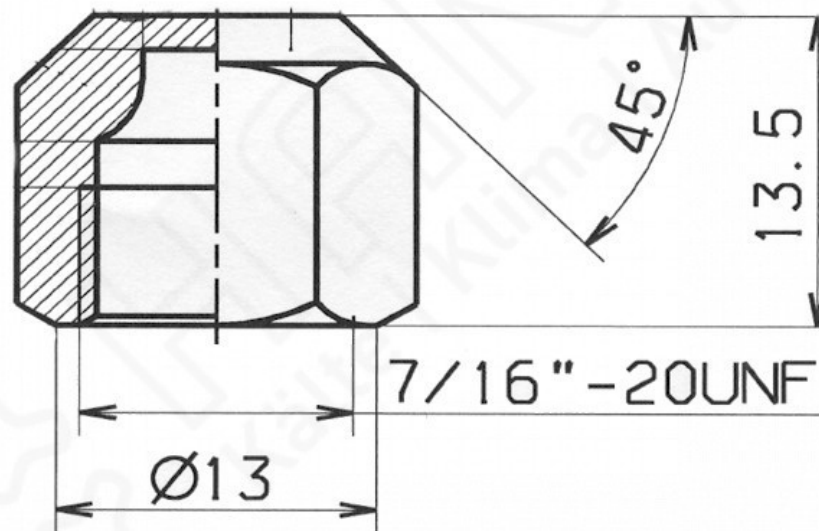
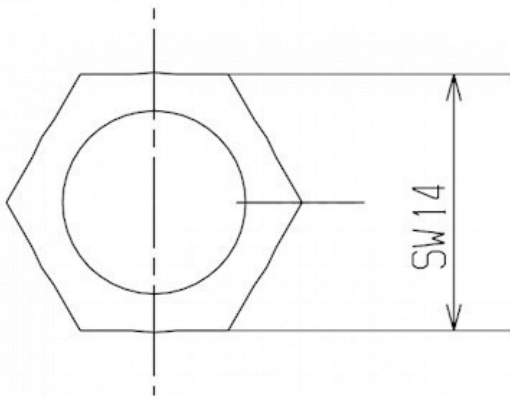

HANSA 2776868050